

NEW

Radiometrix

Hartcran House, 231 Kenton Lane, Harrow, HA3 8RP, England

Tel: +44 (0) 20 8909 9595, Fax: +44 (0) 20 8909 2233

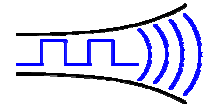

SMX1

Issue 2, 08 April 2009

Small Multi-channel VHF Transceiver

SMX1 is small multi-channel VHF transceiver operating on 173.200MHz-173.325MHz band. It is also available on 151MHz band Australian and 154/173MHz band FCC part 90 allocation.

SMX1 offers a fast-route to custom frequency on any VHF band from 130MHz to 180MHz with 25kHz / 12.5kHz channel spacing.



Figure 1: SMX1-173-5

Features

- Conforms to ETSI EN 300 220-3 and EN 301 489-3
- Conforms to Australian/New Zealand AS/NZS 4268:2003
- North American version compliant with FCC part 90.
- High performance double superhet, 128 channel PLL synthesizer
- Data rates up to 5 kbps for standard module
- Usable range over 1km
- Fully screened. Low profile
- Feature-rich interface (RSSI, analogue and digital baseband)
- Incorporate a 1200baud dumb modem
- Re-programmable via RS232 interface
- Low power requirements

Applications

- Handheld terminals
- Heavy vehicle/machine remote controls
- EPOS equipment, barcode scanners
- Data loggers
- Industrial telemetry and telecommand
- In-building environmental monitoring and control
- High-end security and fire alarms
- Vehicle data up/download

Technical Summary

- Operating frequency: 173.200 – 173.325MHz (UK)
150.825 – 152.450MHz (Australia)
154.45625 - 154.47875MHz (North America)
173.20375 - 173.39625MHz (North America)
- Custom variants from 130 – 180MHz on any 1MHz band
- 128 channels controlled via RS232 interface
- Transmit power: +10dBm (10mW) nominal. Adjustable 1 – 50mW
- Supply range: 4.2V - 16V
- Current consumption: 40mA (10mW) - 65mA (50mW) transmit, 20mA receive
- Data bit rate: 5kbps max. (standard module)
- Receiver sensitivity: -120dBm (for 12 dB SINAD)
- Size: 53 x 32 x 12mm

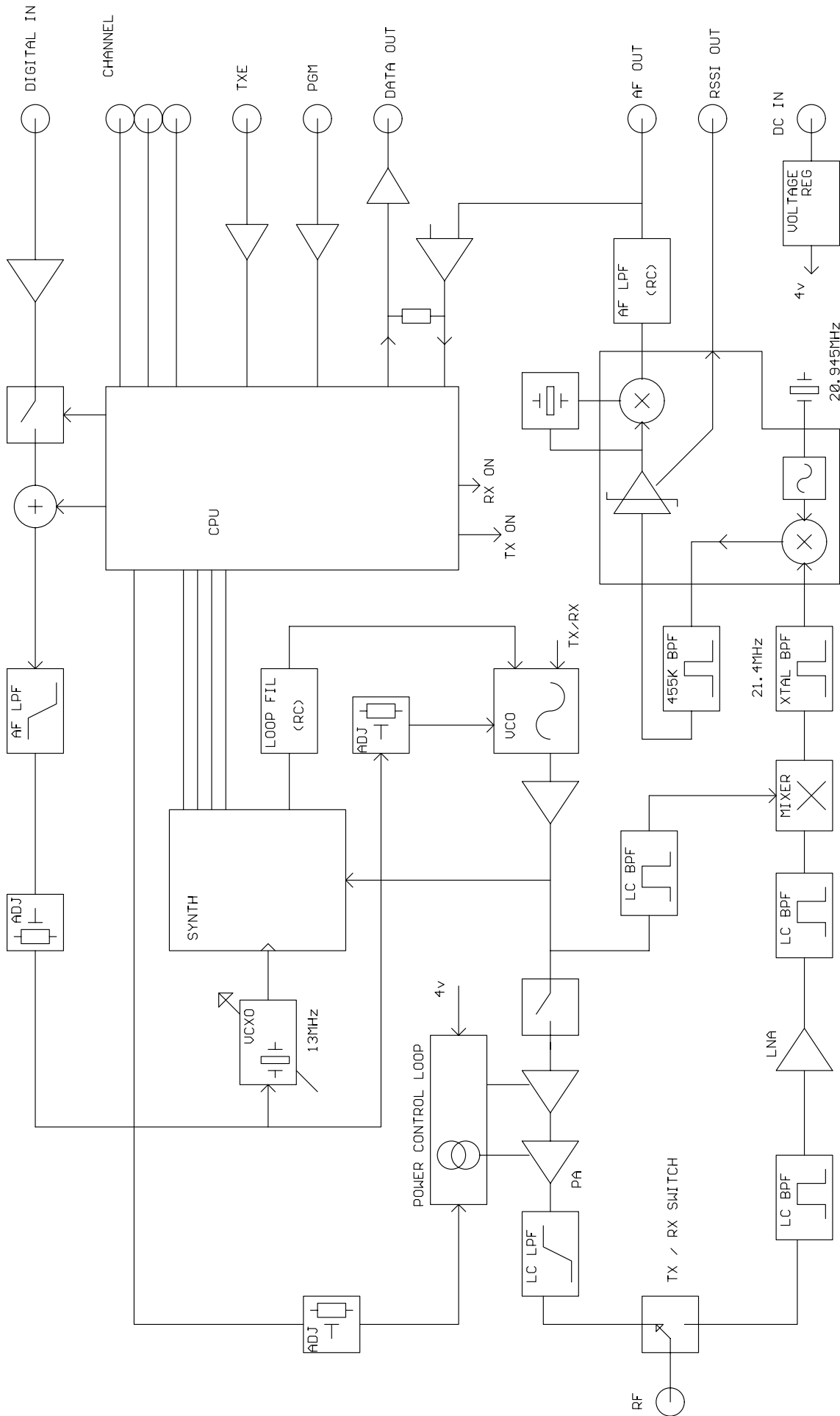

Figure 2: SIMX1 block diagram

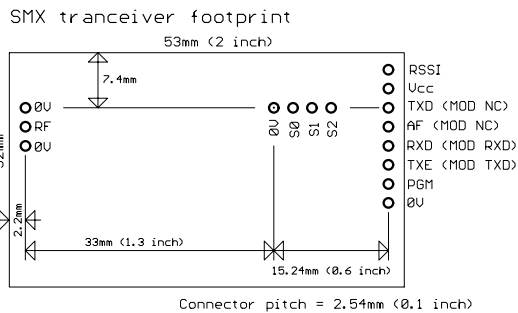

Figure 3: SMX1 footprint (Top) view

Pin Description

Pin	Name	Function
1a	RSSI	DC level between 0.5V and 2.5V. 60dB dynamic range
2a	Vcc	DC supply input. (4.2 – 16V at 40mA nominal)
3a	TXD	DC coupled input for TTL/ CMOS logic.
4a	AF out	500mV p-p audio. DC coupled, approx 0.8V bias.
5a	RXD	Open collector output of data slicer. Need external pull-up
6a	TXE	Transmit enable. Low = RX mode. High = TX. (10k pull down)
7a	PGM	Serial programming / control input (true RS232)
8a	0V	Ground
1b	0V	Ground
2b	S0	Parallel channel select LSB
3b	S1	Parallel channel select
4b	S2	Parallel channel select MSB

Pin description of SMX1 with Modem mode selected

The 'modem' mentioned is a 1200 baud RS232 semi-intelligent unit (Transmit keyed when valid serial data is present, so no separate TX control needed. Coding in the datastream also permits the receiver to ignore noise and only output valid serial data) This is a half duplex unit, so collisions between transmitted and received packets must be dealt with by the user (if transmit data is sent to the unit then a transmit burst commences immediately and the contents of the receive data buffer is lost)

Pin	Name	Function
1a	RSSI	DC level between 0.5v and 2.5v. 60dB dynamic range
2a	Vcc	DC supply input. (4.2 - 16v at 40mA nom.)
3a	NC	Leave unconnected
4a	NC	Leave unconnected
5a	MOD RXD	Open collector RS232 compatible data output
6a	MOD TXD	RS232 data input
7a	PGM	Serial programming/control input (true RS232)
8a	0V	Ground
1b	0V	Ground
2b	S0	Parallel channel select LSB
3b	S1	Parallel channel select
4b	S2	Parallel channel select MSB

NOTES:

1. No inversion occurs between TXD and RXD. However AF out *is* inverted relative to TXD.
2. Parallel channel selects are active LOW and have internal pullups to 4V
3. There are no pullups on the open collector outputs.
4. The software incorporates a 1200 baud modem, compatible with that implemented in other Radiometrix narrowband units (i1200 tones and format). Modem operation is selected by the SETMOD command. TXE pin (6a) becomes an RS232 input, and RS232 compatible data is output on the RXD pin (5a). If true +/- levels are desired then an inverter and a MAX232 should be used on data out.

5. RS232 input pins (6a and 7a) tolerate true +/- levels. No buffering is required.
6. If analogue transmit modulation is needed, then connect a series 1 μ F cap + 500k Ω trimmer in the 'baseband in' circuit. Adjust trimmer for 90% of peak deviation (+/- 2.7KHz) at mean input level.
7. If parallel channel select is not wanted, the 4 pin connector 'b' can be removed
8. For UK version the following channel assignment is supplied:

Channel	Frequency (MHz)
0	173.250
1	173.275
2	173.300
3	173.325
4 -7	173.225 (only used for alarm applications)
8 - 127	173.325

9. For Australian version the following channel assignment is supplied:

Channel	Frequency (MHz)	N value
0	150.825	/LOAD 00 6033
1	150.850	/LOAD 01 6034
2	150.875	/LOAD 02 6035
3	150.900	/LOAD 03 6036
4	150.925	/LOAD 04 6037
5	150.950	/LOAD 05 6038
6	150.975	/LOAD 06 6039
7	151.000	/LOAD 07 6040
8	151.025	/LOAD 08 6041
9	151.050	/LOAD 09 6042
10	151.075	/LOAD 10 6043
11	151.100	/LOAD 11 6044
12	151.125	/LOAD 12 6045
13	151.150	/LOAD 13 6046
14	151.175	/LOAD 14 6047
15	151.200	/LOAD 15 6048
16	151.225	/LOADTB 6049
17 - 65	in sequence starting at CH 17 (151.250)	

10. FCC Part 90.238 Telemetry frequency channels (12.5KHz spacing)

Channels	173MHz band	154MHz band
CH0	173.20375	154.45625
CH1	173.21000	154.46375
CH 2	173.23750	154.47125
CH 3	173.28750	154.47875
CH 4	173.31250	154.45625
CH 5	173.33750	154.46375
CH 6	173.36250	154.47125
CH 7	173.39625	154.47875

SMX1 serial interface commands

2400 baud at RS232 level. 8 bit data, no parity, 1 start bit, 1 or 2 stop bits, No flow control. Transmit (pin 3 on DB9) and Signal Ground (pin 5 on DB9) should be connected to PGM and 0V respectively.

SINGLE nnnnn	Set value of N for single channel operation (value not stored in eeprom)
GOCHAN xx	Serial select of channel xx (0 to 127)
LOADMX xx	Set highest permitted (serial selected) channel xx (others default to ch0)
LOAD aa nnnnn	Set value of N for channel aa (channels 0 to 15)
LOADTB nnnnn	Set value of N for channel 16 (channels 17 to 127 then in sequence)
RVALUE rrrr	Enter value for R register
SETPAR	Channel selected by 3 bit parallel input (0 to 7). Also disables modem
SETSER	Channel selected by most recent 'gochan' operation
SETMOD	Enable internal modem. Frequency selected by most recent 'gochan' or 'single'
<cr>	Process entry
/	Clear all buffers

xx = channel number from 00 to 127

aa = two digit channel number from 00 to 15

nnnnn = synthesizer N register value, (up to 65535)

rrrr = synthesizer R register value, (up to 16383)

$$N = \frac{f_{RF}}{f_{Channelspacing}} = \frac{144MHz}{25kHz} = 5760$$

$$R = \frac{f_{Xtal}}{f_{channelspacing}} = \frac{10MHz}{25kHz}, \text{ So } R=400$$

Notes:

1. A pause of at least 50ms must be allowed between command strings (EEPROM programming time).
SINGLE mode does not store the N value in EEPROM. Therefore the unit is inoperative after a power down until either another valid SINGLE command is received, or mode is changed by a GOCHAN, SETPAR or SETSER command. SINGLE mode is intended for frequency agile applications.
2. /SETPAR command should be issued at the end of channel programming to put the module back into parallel frequency select mode

Condensed specifications

Frequency	Any 2MHz band from 130-180MHz 173.200 - 173.325 MHz UK std. 150.825 - 152.450MHz Australian std 154.45625 - 154.47875MHz (12.5kHz steps) – FCC part 90 173.20375 - 173.39625MHz (12.5kHz steps) - FCC part 90
<i>Frequency stability</i>	+/-5ppm (better than ±1.5kHz)
<i>Channel spacing</i>	25kHz (12.5kHz for North America)
<i>Number of channels</i>	128 channels selected via serial RS232 interface 8 channels selected via 3 frequency select pins
	In UK band only 173.225, 173.250, 173.275, 173.300, 173.325 MHz are used as standard; 151MHz band (Australian) unit has 66 channels
Supply <i>voltage</i>	4.2V-16V
<i>Current</i>	40mA (10mW); 65mA (50mW) transmit 20mA receive (or modem 'idle')
Operating temperature	-20 to +70 °C (Storage -30 to +70 °C)
Size	53 x 32 x 12 mm
Spurious radiations	Compliant with ETSI EN 300 220-3 and EN 300 686
Interface	
<i>user</i>	8 pin 0.1" pitch molex
<i>Power</i>	4 pin 0.1" pitch molex
<i>RF</i>	3 pin 0.1" pitch molex
Recommended PCB hole size	1.2mm (min.)
Intended approval	Australian/New Zealand AS/NZS 4268:2003, US FCC part 90.238 ETSI EN 300 220-3 (radio) and EN 301 489-3 (EMC) standards
Transmitter	
Output power	UK standard +10dBm(10mW) ± 1dB (factory adjustable: 1 - 50mW)
TX on switching time	<50 ms
Modulation type	FM, FSK (F1D, F3D)
TX modulation bandwidth	DC – 3kHz
Deviation	±2.6kHz to ±3kHz
Adjacent channel TX power	-37dBm
Inputs	data (CMOS/TTL compatible)
Receiver	
Sensitivity	-120dBm for 12dB SINAD
<i>image / spurious</i>	-65dB
<i>blocking</i>	-85dB
<i>adjacent channel</i>	-65dB
Outputs	RSSI, Audio, Data
Power on to valid audio	28ms
Power on to stable data out	50ms (for 50:50 mark / space)

- Notes:** 1. The data slicer cannot be depended upon for data waveform frequencies below 250Hz
2. When RX is on and a transmitter keys up, again a 50ms period is required to stabilise data output mark/space. i.e. allow at least 50ms of preamble

Ordering Information

Part No.	Description	Frequency band (MHz)
SMX1-151-5	Australian version	150.825 – 152.450MHz
SMX1-173-5	UK version	173.200 - 173.325 MHz
SMX1-154-5-12K5-FCC	North American version	154.45625 - 154.47875MHz
SMX1-173-5-12K5-FCC	North American version	173.20375 - 173.39625MHz
SMX1-xxx-5	Where xxx is any 2MHz band from 135MHz to 175MHz	

Application circuits

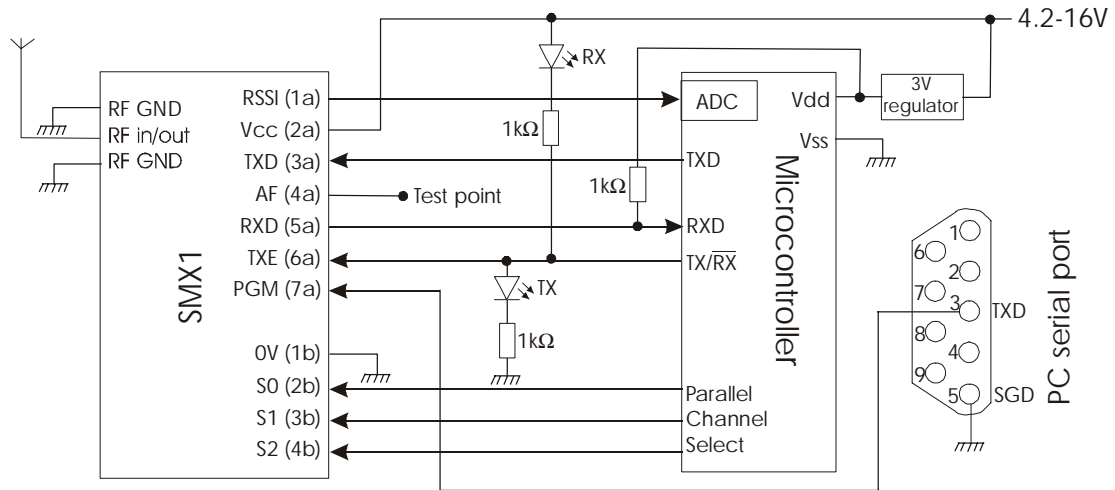

Figure 4: SMX1 interfaced to host microcontroller and serial port for configuration

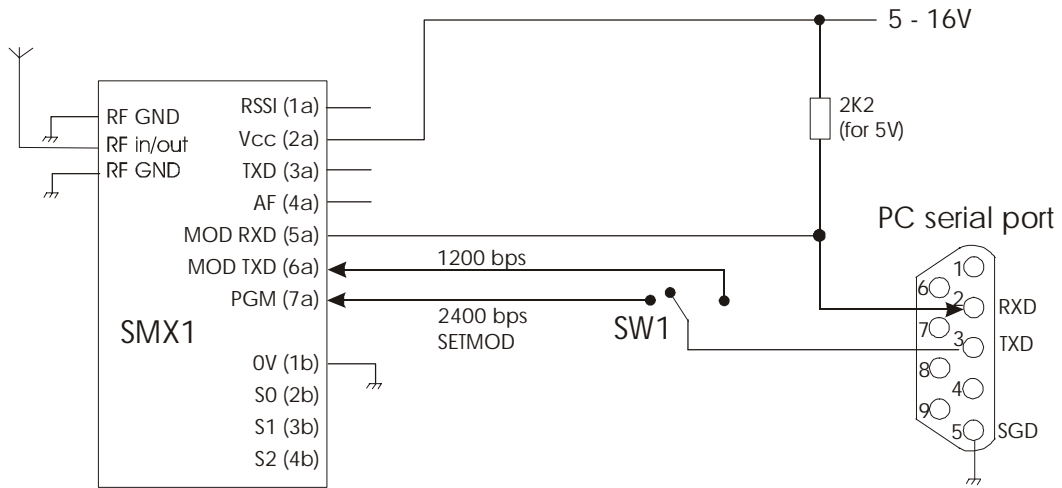

Figure 5: SMX1 interfaced to PC serial port (0V / 5V RS232 level)

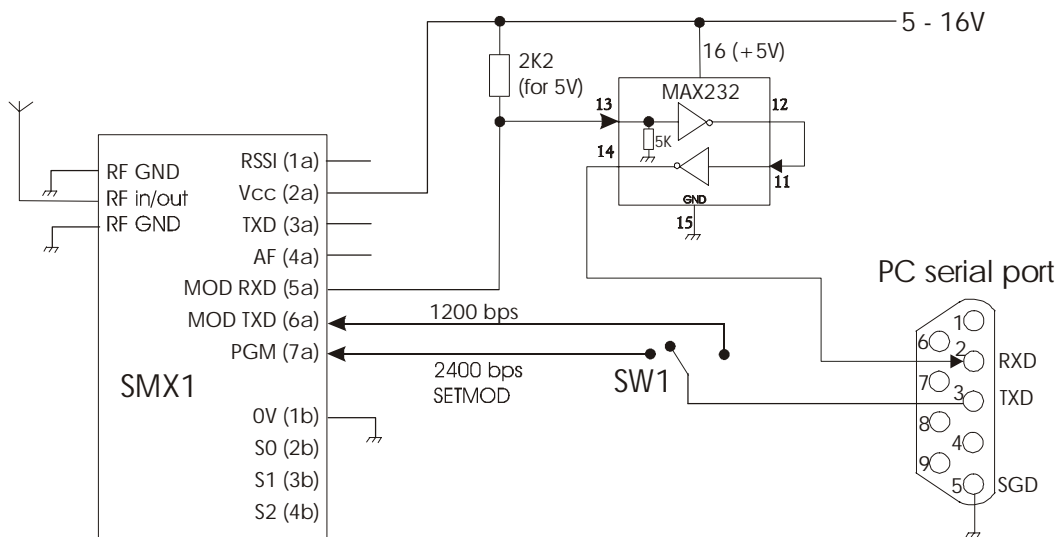

Figure 6: SMX1 interfaced to serial port (+10V / -10V RS232 level)

Radiometrix Ltd
Hartcran House
231 Kenton Lane
Harrow, Middlesex
HA3 8RP
ENGLAND
Tel: +44 (0) 20 8909 9595
Fax: +44 (0) 20 8909 2233
sales@radiometrix.com
www.radiometrix.com

Copyright notice

This product data sheet is the original work and copyrighted property of Radiometrix Ltd. Reproduction in whole or in part must give clear acknowledgement to the copyright owner.

Limitation of liability

The information furnished by Radiometrix Ltd is believed to be accurate and reliable. Radiometrix Ltd reserves the right to make changes or improvements in the design, specification or manufacture of its subassembly products without notice. Radiometrix Ltd does not assume any liability arising from the application or use of any product or circuit described herein, nor for any infringements of patents or other rights of third parties which may result from the use of its products. This data sheet neither states nor implies warranty of any kind, including fitness for any particular application. These radio devices may be subject to radio interference and may not function as intended if interference is present. We do NOT recommend their use for life critical applications. The Intrastat commodity code for all our modules is: 8542 6000.

R&TTE Directive

After 7 April 2001 the manufacturer can only place finished product on the market under the provisions of the R&TTE Directive. Equipment within the scope of the R&TTE Directive may demonstrate compliance to the essential requirements specified in Article 3 of the Directive, as appropriate to the particular equipment. Further details are available on The Office of Communications (Ofcom) web site:

<http://www.ofcom.org.uk/radiocomms/ifi/>

Information Requests
Ofcom
Riverside House
2a Southwark Bridge Road
London SE1 9HA
Tel: +44 (0)845 456 3000 or 020 7981 3040
Fax: +44 (0)20 7783 4033
information.requests@ofcom.org.uk

European Radiocommunications Office (ERO)
Peblingehus
Nansensgade 19
DK 1366 Copenhagen
Tel. +45 33896300
Fax +45 33896330
ero@ero.dk
www.ero.dk