

Radiometrix

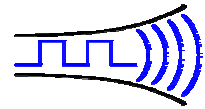

Hartcran House, 231 Kenton Lane, Harrow, HA3 8RP, England

Issue: 1, 01 November 2004 Tel: +44 (0) 20 8909 9595, Fax: +44 (0) 20 8909 2233

BiM3

869/914MHz high speed FM radio transceiver module

The BiM3 radio transceiver module is similar in size and pinout to the BiM2, offering all the advantages of the latter but with reduced power consumption and antenna size. This makes the BiM3 ideally suited to battery-powered portable and handheld equipment requiring the ultimate in miniaturisation.

Two versions are available for applications in Europe or North America.



BiM3-869-64

Features

- ◆ Verified to comply with Radio standard ETSI EN 300 220-3 by UKAS accredited Test Laboratory
- ◆ North American version is designed to comply with FCC part 15.249 regulations
- ◆ Usable range to 120 metres external, 30 metres in building
- ◆ Data rates up to 64kb/s
- ◆ Crystal controlled PLL FM circuitry for both Tx and Rx
- ◆ SAW front end filter and full screening
- ◆ Low profile with small footprint
- ◆ Low power requirements: 3.3V or 5V nominal at <15mA

The BiM3 is a half duplex radio transceiver module for use in high-speed bidirectional data transfer applications at ranges up to 120 metres. Two frequency variants are available for licence-exempt operation in either the European 868-870MHz or North American 902-928MHz bands. The standard version is designed to operate from 4V–5.5V, however a low voltage (3.3V–4V) version is also available.

The small footprint of 33 x 23mm and low profile of 4mm facilitate convenient integration onto a PCB. The raw data rate capability of 64kb/s will support high data throughput in 'streaming' applications, or alternatively allows minimal airtime utilisation in multi-node scanning networks.

Applications

- ◆ PDAs, organisers and laptops
- ◆ Handheld terminals
- ◆ EPOS equipment, barcode scanners, belt clip printers
- ◆ Data loggers
- ◆ Audience response systems
- ◆ In-building environmental monitoring and control
- ◆ Security and fire alarms
- ◆ Restaurant ordering systems
- ◆ Vehicle data up/download

Functional overview

The transmit section of the BiM3 consists of a frequency modulated crystal locked PLL feeding a buffer amplifier and RF filter. Operation is controlled by a Tx select line, the transmitter achieving full RF output typically within 1ms of this line being pulled low. Modulation is applied at the TXD input and may be either a serial digital stream at the same level as the module supply rail (digital drive) or a high level analogue waveform with a peak-to-peak amplitude close to the module supply level (linear drive). Modulation shaping is performed internally by a 2nd order low pass filter which minimises spectral spreading. The RF output is filtered to ensure compliance with the appropriate regulations and fed via a fast Tx/Rx changeover switch to the 50Ω antenna pin.

The receive section is a single conversion FM superhet with an IF of 10.7MHz. A SAW filter between the antenna switch and the receiver front-end provides image rejection and suppression of other unwanted out-of-band signals. Like the transmitter, the receiver is controlled by its own active low select line and will power up in typically 5ms. A post-detection 2nd order 35kHz LPF establishes the signal bandwidth and ensures clean operation of the subsequent adaptive data slicer. The slicer has a 2ms averaging time constant and is optimised for balanced data, e.g. bi-phase codes. A received signal strength (RSSI) output with some 75dB of range is provided.

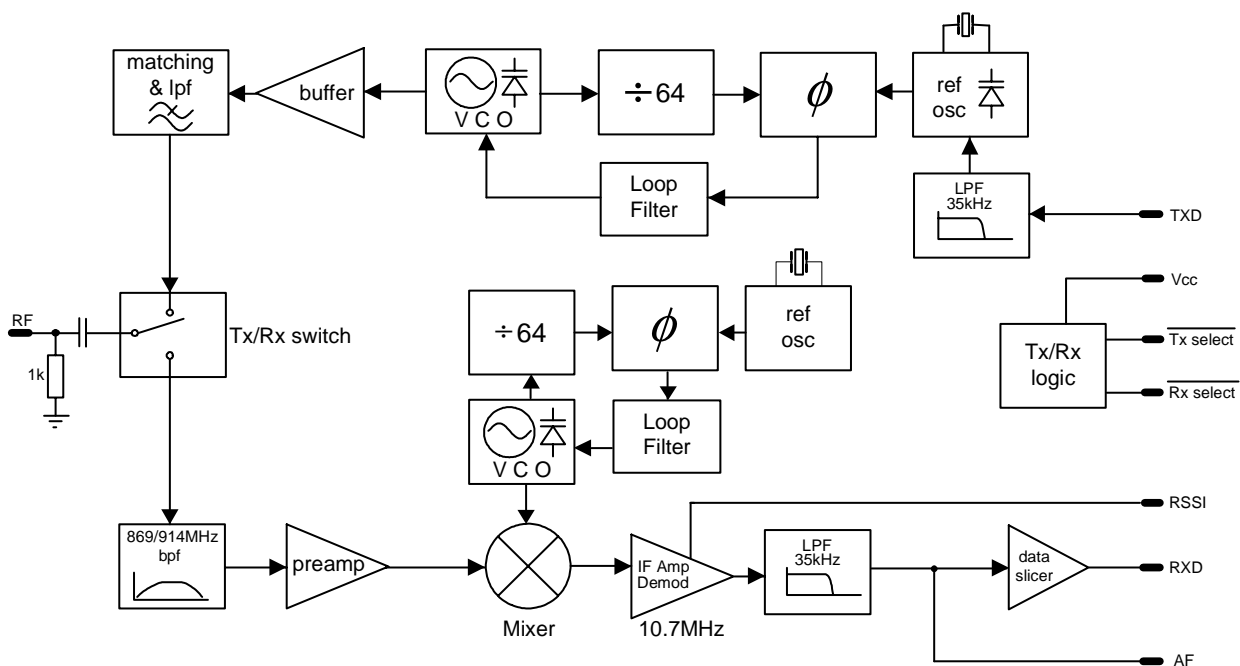

Fig.1: Block diagram

Pin description

RF GND pins 1 & 3

RF ground pins, internally connected to the module screen and to pins 5, 9, 10 & 18 (0V). These pins should be connected directly to the RF return path (e.g. coax braid, main PCB ground plane etc.)

Antenna pin 2

50Ω RF connection to the antenna. Internal 1kΩ resistor to ground provides a DC path for static discharge purposes. See pages 7-8 for details of suitable antennas and feeds.

0V (GND) pins 5, 9, 10 & 18

Supply ground connection and screen.

RSSI pin 11

Received Signal Strength Indicator with >65dB range, operational when Rx is active. Output voltage nominally 0.25-0.3Vdc (no signal), 1.1Vdc (maximum). See Fig.3 for typical characteristics.

RXD *pin 12*

Digital output from internal data slicer. The output is a squared version of the signal on pin 13 (AF) and may be used to drive a decoder directly. The data is true data, i.e. as fed to the transmitter, and is nearly rail-to-rail reference the supply voltage. External load should be >50kΩ // <100pF.

AF *pin 13*

Buffered & filtered analogue output from FM demodulator. 450mV_{p-p} with standing DC bias of 1V. Useful for test purposes or for driving linear decoders. External load should be >50kΩ // <100pF. **NOTE:** AF waveform from this pin is **inverted**.

TXD *pin 14*

This DC-coupled transmitter modulation input will accept either serial digital data or high level linear signals. See page 5 for suggested drive methods. Input impedance >50kΩ.

TX select *pin 15*

Active-low Transmit select. 10kΩ internal pull-up to Vcc.

RX select *pin 16*

Active-low Receive select. 10kΩ internal pull-up to Vcc.

Pin 15 TX	Pin 16 RX	Function
1	1	Power down (<10μA)
1	0	Receiver enabled
0	1	Transmitter enabled
0	0	Self test loop-back*

*Loop-back allows the receiver to monitor the transmitted signal. The receiver will not receive external signals whilst the transmitter is enabled, however the full Tx RF output will be present at pin 2.

Vcc *pin 17*

DC +ve supply pin. +3.0 to +5.5 volts @ <15mA. The supply must be clean, <20mV_{P-P} ripple. A 2.2μF decoupling capacitor and 10Ω series resistor are used internally to filter the supply.

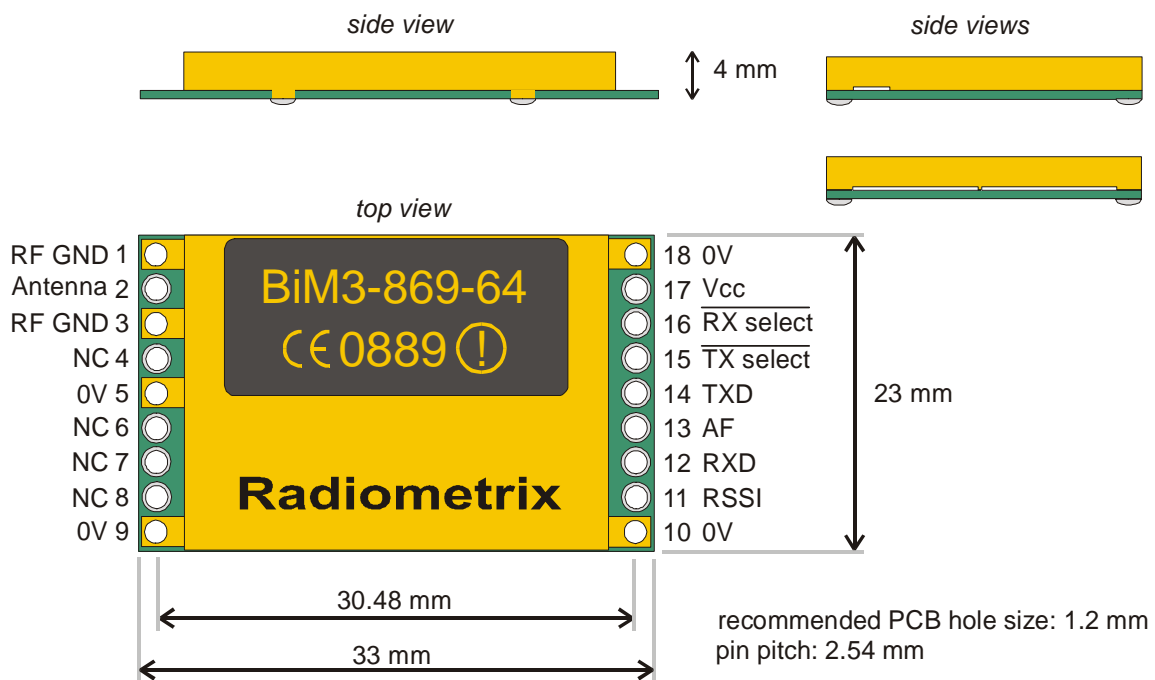

Weight: 5g (typical, with pins)

Fig.2: Physical dimensions

Absolute maximum ratings

Exceeding the values below may cause permanent damage to the module.

Operating temperature	-20°C to +70°C
Storage temperature	-40°C to +100°C
Vcc (pin 17, 5V version)	-0.1V to +6.0V
Vcc (pin 17, 3V version)	-0.1V to +4.5V
All other pins	-0.1V to +(Vcc+0.6)V
Antenna (pin 2)	±8V DC, +10dBm RF

Performance specifications

Figures apply to standard version @ Vcc=5.0V, temperature +20°C, unless stated.

DC & interface parameters	pin	min.	typ.	max.	units	notes
Supply voltage (<i>std version</i>)	17	4.0	5.0	5.5	V	
Supply voltage (<i>3V version</i>)	17	-	3.3	4.0	V	
Tx supply current (<i>all versions</i>)	17	7.5	9	11	mA	Vcc=5V/3.3V
Rx supply current (<i>std version</i>)	17	11.5	12.5	14	mA	Vcc=5.0V
Rx supply current (<i>3V version</i>)	17	9	10	11.5	mA	Vcc=3.3V
AF output DC level	13	0.8	1.0	1.2	V	
AF output level	13	350	450	550	mV p-p	AF inverted
RSSI output, no signal	11	0.1	0.25	0.4	V	
RSSI output, max indication	11	0.9	1.1	1.2	V	-30dBm RF
Data output high, 100µA source	12	-	Vcc-0.6	-	V	RXD high
Data output low, 100µA sink	12	-	0.4	-	V	RXD low
TX & RX select: high (<i>deselect</i>)	15, 16	Vcc-0.5		Vcc	V	
low (<i>select</i>)	15, 16	0		0.5	V	
Internal select pull-ups	15,16	-	10	-	kΩ	
TXD: high	14	Vcc-0.5		Vcc	V	
low	14	0		0.5	V	

RF parameters	pin	min.	typ.	max.	units	notes
General						
Antenna pin impedance	2	-	50	-	Ω	Tx or Rx
RF centre frequency	-	-	869.85	-	MHz	EU version
RF centre frequency	-	-	914.50	-	MHz	US version
Transmitter						
RF power output (<i>all versions</i>)	2	-2	+1	+3	dBm	Vcc=5V/3.3V
Initial frequency accuracy	-	-25	0	+25	kHz	
Overall frequency accuracy	-	-50	0	+50	kHz	
FM deviation	-	30	40	50	kHz	
Modulation bandwidth	-	DC	-	35	kHz	
Modulation distortion	-	-	5	10	%	
TX harmonics	2	-	-	-40	dBm	
TX spectral bandwidth @-40dBc	2	-	-	250	kHz	worst case
Receiver						
RF sensitivity, 10dB S/N	2, 13	-100	-105	-	dBm	
RF sensitivity, 1ppm BER	2, 12	-92	-97	-	dBm	
RSSI threshold	2, 11	-	-115	-	dBm	
IF bandwidth	-	-	180	-	kHz	
AF bandwidth	13	-	35	-	kHz	
Image rejection (f _{RF} -21.4MHz)	2	35	>40	-	dB	

<i>Receiver (cont'd)</i>						
RX LO leakage, conducted	2	-	-	-57	dBm	
RX LO leakage, radiated	-	-	-	-57	dBm	
Ultimate (S+N)/N	13	-	>40	-	dB	-70dBm RF
Initial frequency accuracy	-	-15	0	+15	kHz	

Baseband parameters	pin	min.	typ.	max.	units	notes
<i>Tx → Rx</i>						
Linear baseband bandwidth	13	0.08	-	32	kHz	TXD to AF
Balanced code bit rate	12	-	-	64	kb/s	
Time between code transitions	14	15.6	-	1000	μs	
Averaged code mark:space	14	30	50	70	%	in any 2ms
<i>Dynamic Timing</i>						
<i>Rx power up with signal present</i>						
Power up to valid RSSI, t _{PU-RSSI}	11	-	5	6	ms	
Power up to stable data, t _{PU-data}	12	-	4	6	ms	
<i>Signal applied with Rx on</i>						
Signal to valid RSSI, t _{sig-RSSI}	11	-	1.6	2	ms	
Signal to stable data, t _{sig-data}	12	-	3	4	ms	
TX power up to full RF	2	-	1	1.5	ms	

Modulation formats and range extension

The module will produce the specified FM deviation with a 2-level digital input to TXD which toggles between 0V and the supply rail (5V or 3.3V, depending on the version). Reducing the amplitude of the data input from this value (usually as a result of reducing the supply voltage) reduces the transmitted FM deviation, typically to ±30kHz minimum if running the 5V version at 4.0V. The receiver will cope with this quite happily and no significant degradation of link performance should be observed.

TXD is normally driven directly by logic levels but will also accept analogue drive, e.g. 2-tone signalling. In this case pin 14 should be DC-biased to half supply rail, with the modulation AC-coupled. The instantaneous modulation voltage must not swing beyond either supply rail, or waveform distortion and excessive FM deviation could result. The varactor modulator in the BiM3 transmitter introduces some 2nd harmonic distortion which may be reduced if necessary by predistortion of the analogue waveform.

At the other end of the link the AF output (pin 13) can be used to drive an external decoder directly.

Although the module baseband response extends down to DC, it is not advisable to use data containing a DC component. This is because frequency errors and drifts between the transmitter and receiver occur in normal operation, resulting in DC offset errors on the audio output.

The BiM3 incorporates lowpass baseband filters designed to give an overall system bandwidth of 32kHz. This is suitable for transmission of data at raw bit rates up to 64kb/s. The adaptive data slicer has been designed to accept a maximum time between data transitions of 1ms in order to keep settling times reasonably fast for battery-economised operation. RXD output on pin 12 is “true” sense, i.e. as originally fed to the transmitter.

In applications such as longer range fixed links where data speed is not of primary importance, a significant increase in range can be obtained by using the slowest possible data rate together with filtering to reduce the receiver bandwidth to the minimum necessary. In these circumstances the BiM3 audio output should be used to drive an external filter and data slicer.

The audio output waveform on pin 13 is inverted, i.e. in the opposite sense to that originally fed to the transmitter. This should be borne in mind if using the AF output to drive other circuitry.

Received Signal Strength Indicator (RSSI)

The BiM3 receiver incorporates a wide range RSSI which measures the strength of an incoming signal over a range of 65dB or more. This allows assessment of link quality and available margin and is useful when performing range tests.

The output on pin 11 of the module has a standing DC bias of typically 0.25-0.3V with no signal, rising to typically 1.1V at maximum indication. The RSSI output source impedance is high (~20k Ω) and external loading should therefore be kept to a minimum.

Typical RSSI characteristics are shown below:

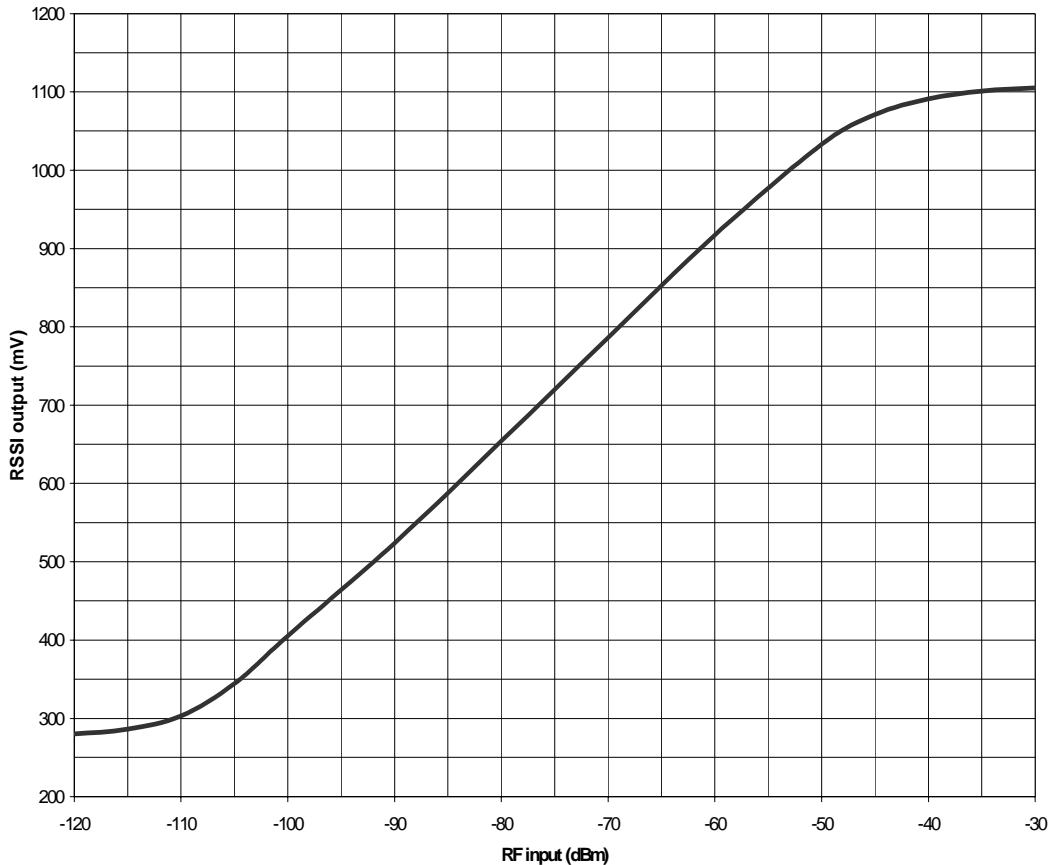

Fig.3: Typical RSSI response curve

To ensure a reasonably fast response the RSSI has limited internal decoupling of 10nF to ground. This may result in a small amount of audio ripple on the DC output at pin 11 of the module. If this is a problem further decoupling may be added at the expense of response speed, in the form of a capacitor from pin 11 to ground. There is no upper limit on the value of this capacitor.

Operating the BiM3 in close proximity to other transmitters

The BiM3 receiver may start to overload if the on-frequency RF input level exceeds -10dBm, with resultant degradation in performance (normally manifested as a drop in range). It is sometimes possible to exceed this level if operating two or more modules with their respective antennas in very close proximity, or if operating the BiM3 near any transmitter on the same or a nearby frequency.

Expected range

Predicting the range obtainable in any given situation is notoriously difficult since there are many factors involved. The main ones to consider are as follows:

Type and location of antennas in use (see below)
Type of terrain and degree of obstruction of the link path
Sources of interference affecting the receiver
“Dead” spots caused by signal reflections from nearby conductive objects
Data rate and degree of filtering employed (see page 5)

Assuming the maximum 64kb/s data rate and ¼-wave whip antennas on both transmitter and receiver, the following ranges may be used as a rough guide only:

Cluttered/obstructed environment, e.g. inside a building	:	30-50m
Open, relatively unobstructed environment	:	120-200m

It must be stressed, however, that range could be much greater or much less than these figures. Range tests should *always* be performed before assuming that a particular range can be achieved in any given application.

Antenna considerations and options

The choice and positioning of transmitter and receiver antennas is of the utmost importance and is the single most significant factor in determining system range. The following notes are intended to assist the user in choosing the most effective arrangement for a given application.

Nearby conducting objects such as a PCB or battery can cause detuning or screening of the antenna which severely reduces efficiency. Ideally the antenna should stick out from the top of the product and be entirely in the clear, however this is often not desirable for practical or ergonomic reasons and a compromise may need to be reached. If an internal antenna must be used, try to keep it away from other metal components and pay particular attention to the “hot” end (i.e. the far end), as this is generally the most susceptible to detuning. The space around the antenna is as important as the antenna itself.

Microprocessors and microcontrollers tend to radiate significant amounts of radio frequency hash, which can cause desensitisation of the receiver if its antenna is in close proximity. 900MHz is generally less prone to this effect than lower frequencies, but problems can still arise. Things become worse as logic speeds increase, because fast logic edges are capable of generating harmonics across the UHF range which are then radiated effectively by the PCB tracking. In extreme cases system range can be reduced by a factor of 3 or more. To minimise any adverse effects, situate the antenna and module as far as possible from any such circuitry and keep PCB track lengths to the minimum possible. A ground plane can be highly effective in cutting radiated interference and its use is strongly recommended.

A simple test for interference is to monitor the receiver RSSI output voltage, which should be the same regardless of whether the microcontroller or other logic circuitry is running or in reset.

Two types of antenna are recommended for use with the BiM3:

Whip (¼-wave). This consists simply of a piece of wire or rod connected to the module at one end. The lengths given below are from module pin to antenna tip including any interconnecting wire or tracking (but **not** including any 50Ω coax or microstrip connection). This antenna is simple, cheap, easy to set up and performs well. It is especially effective when used with a ground plane, which in practice is often provided by the main PCB or by a metal case.

Optimum antenna lengths are slightly different for 869MHz (82mm) and 914MHz (78mm), however a compromise of 80mm is quite acceptable for equipment designed to accommodate both frequencies.

Base-loaded whip. In applications where space is at a premium a shortened whip may be used, tuned by means of a coil inserted at the base. This coil may be air-wound for maximum efficiency, or a small SMT inductor can be used. The value must be empirically chosen to tune the particular length of whip for best results “in situ”, making this antenna more difficult to set up. Radiated power will generally be slightly less than that obtained from a ¼-wave whip.

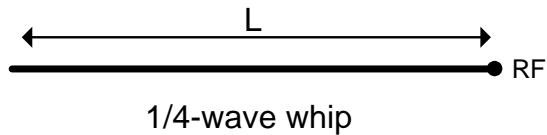

1/4-wave whip

wire, rod, PCB track
or a combination of these
 $L \text{ (mm)} = 71250 / \text{freq(MHz)}$



Base-loaded whip

shortened wire, rod, PCB track etc.
with loading coil.
SMT inductor may be used if reqd.

Fig.4: Antenna configurations

Other types of antennas are feasible but tend to have drawbacks at these frequencies. Helical and tuned loop antennas are both very compact but tricky to set up, and tend to be impractical at 900MHz because of their very small size. Microstrip patch antennas are relatively large in area, directional, and have gain. These characteristics can be useful but tend to preclude FCC Part 15.249 applications, as it is easily possible to exceed the limit for radiated field strength.

Type Approval requirements: Europe

The modules comply with the requirements of the R&TTE Directive (including standards EN 300 220-3 and EN 301 489-3) when used in accordance with the information contained herein. The following provisos apply:

- 1) The modules must not be modified or used outside their specification limits.
- 2) The modules may only be used to transfer digital or digitised data. Analogue speech and/or music are not permitted.
- 3) The equipment in which the BiM3 is used must carry all necessary external labelling to meet the requirements of the R&TTE directive.
- 4) The BiM3 has not been tested with antennas having gains greater than that of a quarter-wave whip. The use of such antennas may require further R&TTE approval.

Type Approval requirements: USA

Radiometrix BiM3 modules are sold as component devices requiring external components and connections to function. They are designed to comply with FCC Part 15.249 regulations, however they are not approved by the FCC. The purchaser understands that FCC approval will be required prior to the sale or operation of any device containing these modules.

- 1) Antennas must be either permanently attached (i.e. non-removable) or must use a connector which is unique or not commonly available to the public.
- 2) The user must ensure that the BiM3/antenna combination does not radiate more than the maximum permitted field strength of 50mV/m at 3m distance (FCC Part 15.249). This is equivalent to an effective radiated power (ERP) of 0.75mW (-1.25dBm) approx.
- 3) The appropriate FCC identifying mark and/or part 15 compliance statement must be clearly visible on the outside of the equipment containing the module(s).

Module mounting considerations

Good RF layout practice should be observed. In particular, any ground return required by the antenna or feed should be connected directly to the RF GND pins at the antenna end of the module, and not to the OV pins which are intended as DC grounds only. All connecting tracks should be kept as short as possible to avoid any problems with stray RF pickup.

If the connection between module and antenna does not form part of the antenna itself, it should be made using 50Ω microstrip line or coax or a combination of both. It is desirable (but not essential) to fill all unused PCB area around the module with ground plane.

Variants and ordering information

BiM3 modules are manufactured in the following variants as standard (all with pins fitted):

*For European applications in the 868-870MHz band:
Frequency = 869.85MHz*

BiM3-869-64-5V	Standard version	4.0-5.5V (5V nominal)
BiM3-869-64-3V	Low voltage version	3.3-4.0V (3.3V nominal)

*For North American applications in the 902-928MHz band:
Frequency = 914.5MHz*

BiM3-914-64-5V	Standard version	4.0-5.5V (5V nominal)
BiM3-914-64-3V	Low voltage version	3.3-4.0V (3.3V nominal)

Other variants can be supplied to customer requirements, on different frequencies and/or optimised for specific data speeds and formats, with or without pins. Minimum order quantities apply. Please consult the factory for further information.

Notes

Radiometrix Ltd

**Hartcran House
231 Kenton Lane
Harrow, Middlesex
HA3 8RP
ENGLAND**

Tel: +44 (0) 20 8909 9595

Fax: +44 (0) 20 8909 2233

sales@radiometrix.com

www.radiometrix.com

Copyright notice

This product data sheet is the original work and copyrighted property of Radiometrix Ltd. Reproduction in whole or in part must give clear acknowledgement to the copyright owner.

Limitation of liability

The information furnished by Radiometrix Ltd is believed to be accurate and reliable. Radiometrix Ltd reserves the right to make changes or improvements in the design, specification or manufacture of its subassembly products without notice. Radiometrix Ltd does not assume any liability arising from the application or use of any product or circuit described herein, nor for any infringements of patents or other rights of third parties which may result from the use of its products. This data sheet neither states nor implies warranty of any kind, including fitness for any particular application. These radio devices may be subject to radio interference and may not function as intended if interference is present. We do NOT recommend their use for life critical applications.

The Intrastat commodity code for all our modules is: 8542 6000

R&TTE Directive

After 7 April 2001 the manufacturer can only place finished product on the market under the provisions of the R&TTE Directive. Equipment within the scope of the R&TTE Directive may demonstrate compliance to the essential requirements specified in Article 3 of the Directive, as appropriate to the particular equipment.

Further details are available on The Office of Communications (Ofcom) web site:

http://www.ofcom.org.uk/licensing_numbering/radiocomms/licensing/licensing_policy_manual/

Information Requests

Ofcom

Riverside House

2a Southwark Bridge Road

London SE1 9HA

Tel: +44 (0)845 456 3000 or 020 7981 3040

Fax: +44 (0)20 7783 4033

information.requests@ofcom.org.uk

European Radiocommunications Office (ERO)

Pebblinghus

Nansensgade 19

DK 1366 Copenhagen

Tel. +45 33896300

Fax +45 33896330

ero@ero.dk

www.ero.dk
