

NEW

Radiometrix

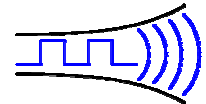

03 March 2009

Hartcran House, 231 Kenton Lane, Harrow, HA3 8RP, England
Tel: +44 (0) 20 8909 9595, Fax: +44 (0) 20 8909 2233

AFS2-458

500mW UHF RF power amplifier

AFS2 amplifier module is intended to increase the transmitted power of a Radiometrix multi channel TR2M transceiver module. It provides transmit and receive paths, and can be simply 'dropped into' the aerial connection. The AFS2 may be usable with other 100mW output devices, but no guarantees can be offered.



Figure 1: AFS2-458

AFS2 : 500mW power amplifier + RF switch

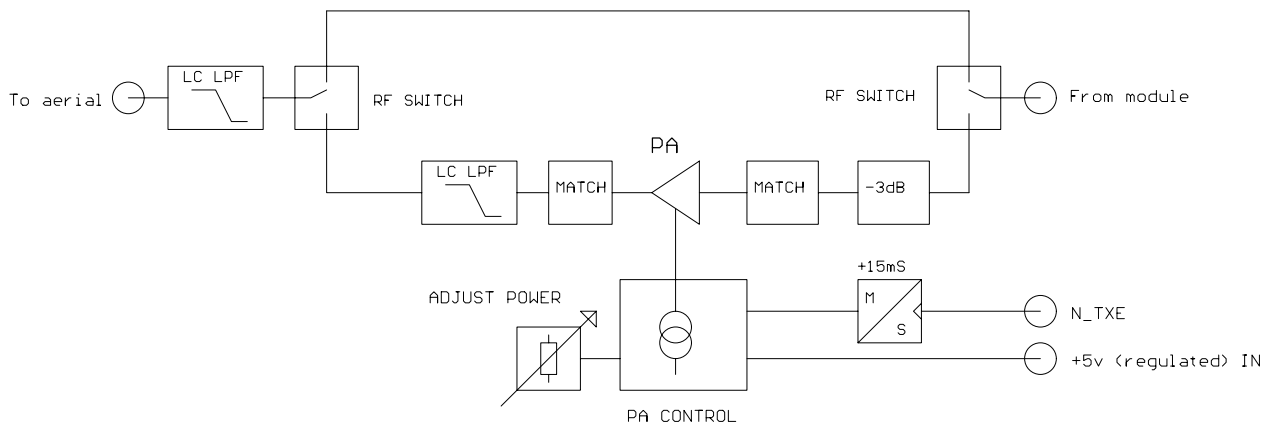

Figure 2: AFS2 block diagram

User interface

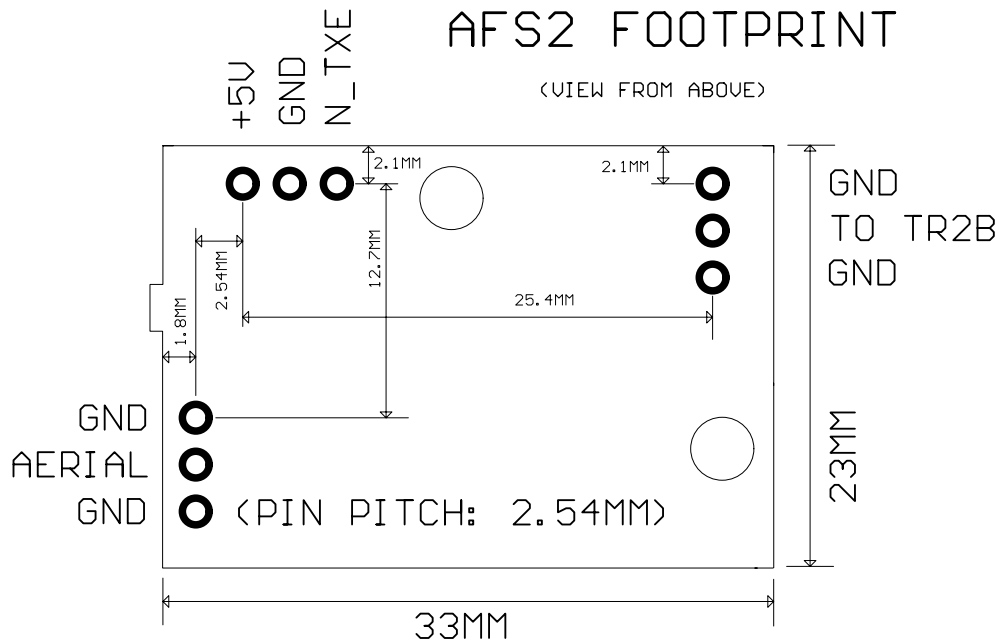

Figure 3: AFS2 pin-out and dimension

Pin description

Pin	Name	Function
RF		
1	RF GND	RF Ground
2	Aerial	RF connection to aerial (50 Ω)
3	RF GND	RF Ground
User		
1	Vcc	Regulated +5v supply, at <250mA
2	0V	Supply Ground
3	$\overline{\text{TXE}}$	Transmit mode enable (active low, 100K pullup to +5v)
RF Module		
1	RF GND	RF Ground
2	RF in/out	RF connection to radio module
3	RF GND	RF Ground

NOTES:

1. This amplifier expects a 100mW power level to be output from the radio on transmit.
2. The $\overline{\text{TXE}}$ line should be tied to the TR2M $\overline{\text{TXE}}$ input. When this line is asserted (low) the amplifier is turned on (drawing 280-300mA) and the RF switching connects it between the module and the aerial. When it is inactive (high or floating) a low loss path is provided for the rx signals, from aerial to the module.
3. If a low power transmit mode is needed, the receive path is bidirectional, and capable of carrying up to 100mW of power. In this case the radio must be set to transmit, but the AFS2 pin $\overline{\text{TXE}}$ must be left in the inactive (high) state.
4. Following the return of $\overline{\text{TXE}}$ to inactive (high), the AFS2 remains in transmit mode for another 15mS, to allow the output of the radio to ramp down, before changing over to receive mode.
5. This unit requires a regulated +5v rail, during transmit, and during receive.
6. This version cannot be used with in i1200 modem mode, unless a separate means of driving the $\overline{\text{TXE}}$ pin is provided. (see relevant application notes)
7. This is a 500mW output product. Good grounding (mount onto a groundplane and tack solder all can walls to this), good quality aerals, properly mounted, and a low impedance power supply are required if full performance is to be reliably obtained. If feasible, we recommend mounting the module, and the board it is on, inside a metal enclosure, with the RF cable taken to a bulkhead connector. All signal and power feeds should be filtered and/or decoupled.

Failure to observe these measures can cause modulation distortion ('recirculation' effects) or instability. Also be aware of the effect that the strong RF fields generated by this device (and it's aerial) can have upon other adjacent circuitry if this is not properly screened, filtered or otherwise protected. Regulators, sensitive analogue circuitry, and microprocessors seem especially interference prone.

Condensed specifications

Frequency	458MHz (standard) Any 10MHz wide segment within 420-470MHz band
<i>Transmitter</i>	
<i>Output power</i>	500mW +/- 1dB (250mW by special order)
<i>TX hold time</i>	15mS after TXE goes high
TX spuri	<-40dBm
Receive path loss	<1dB (bi directional)
Supply	<i>voltage</i> +5V regulated
	<i>Current</i> 250mA transmit
	<2mA receive (TXE high or floating)
Operating temperature	-20 to +70 °C (Storage -30 to +70 °C)
Size	33 x 23 x 9 mm
Spurious radiations	Compliant with ETSI EN 300 220-3 and EN 301 489-3
Interface	<i>User</i> 3 pin 0.1" pitch molex
	<i>RF Module</i> 3 pin 0.1" pitch molex
	<i>RF</i> 3 pin 0.1" pitch molex

Radiometrix Ltd
Hartcran House
231 Kenton Lane
Harrow, Middlesex, HA3 8RP, ENGLAND
Tel: +44 (0) 20 8909 9595, Fax: +44 (0) 20 8909 2233
sales@radiometrix.com, www.radiometrix.com